

# Frustration-Free 3D Printing

Everything You Need  
To Know To Use One

Tom Hammond  
tominohio@gmail.com



OHIO  
LIGHTING  
MINI

# A Picture Is Worth a Thousand Words

OHIO  
LIGHTING  
MINI



[itwinkle.org > Support > Christmas Lights Users Groups](https://www.itwinkle.org/Support/Christmas-Lights-Users-Groups)

# Overview

## Preparing Your Printer

- Why 3D printers are useful
- Parts repositories
- Filament types
- Print bed preparation
- First layer is everything!

## Using the Software

- Slicer choices
- Orientation, scaling, cutting
- Supports, brims, skirts
- Layer height, walls, infill
- Printing

# Why 3D Printers Are Useful



# Why 3D Printers Are Useful

- House clips
  - Gutter, shingle, eaves, siding
- Conduit attachments
  - House mounts, pixel clips
- Prop mounts
  - House/yard mounts, coro braces

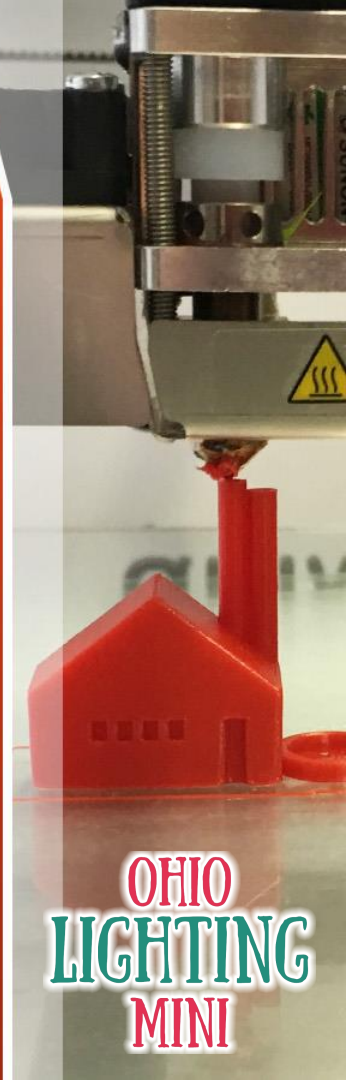
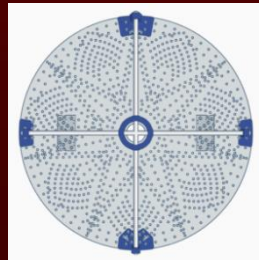
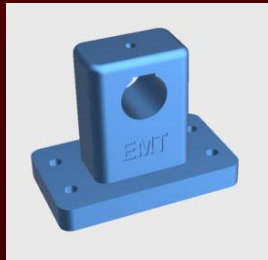

OHIO  
LIGHTING  
MINI

# Why 3D Printers Are Useful

- Tools
  - Pixel pushers/jigs
- New props
  - Stars, spinners, candy canes
- Modify traditional props
  - Spiral trees, RBLs
- Controller/power supply mounts



OHIO  
LIGHTING  
MINI

# TRIVIA BREAK!

Which year was 3D printing patented with a device that was produced shortly after?

1986

1992

2007

2010

# Parts Repositories



# Parts Repositories

- Facebook

  - [Official xLights Sharing Group](#)

  - [Official xLights Support Group](#)

  - [3D Printing For True Holiday Light Enthusiasts](#)

  - [3D Printing For Holiday Lighting Enthusiasts Group](#)

- 3D printing repositories

  - [thingiverse.com](http://thingiverse.com) ([DIY Christmas](#))

  - [printables.com](http://printables.com)

  - [makerworld.com](http://makerworld.com)

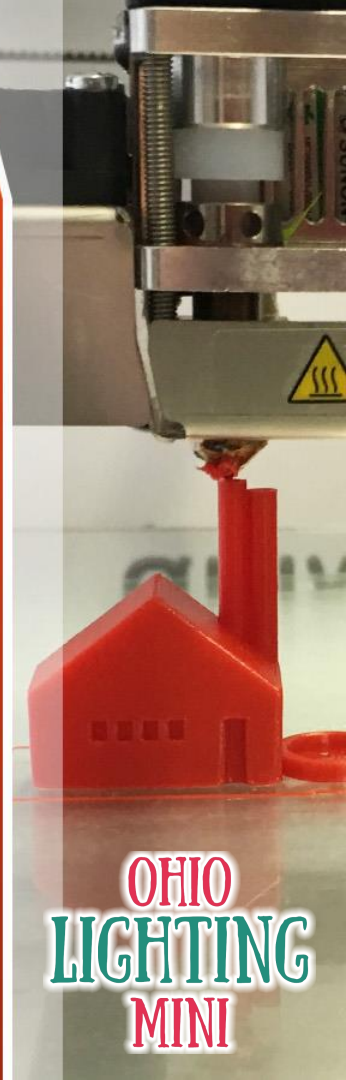

# Where To Find Shapes

- Christmas lighting vendors

Flash The Neighbors

Inspire Light Shows

JustinZDesign

SFL Designs

Your Pixel Store

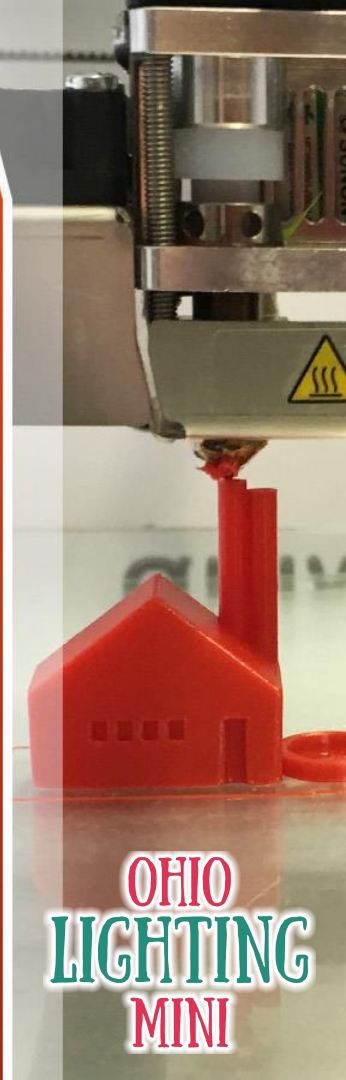

# Filament Types



# Filament

Glass transition temperature

- PLA

Outside temps to 131F, somewhat brittle, easy to print



- PETG

Outside temps to 167F, stronger than PLA, UV safe, stronger, UV safe, somewhat easy to print

- ABS

Outside temps to 201F, strong, not UV safe, warping & cracking, difficulty to print, unsafe odor (VOCs)

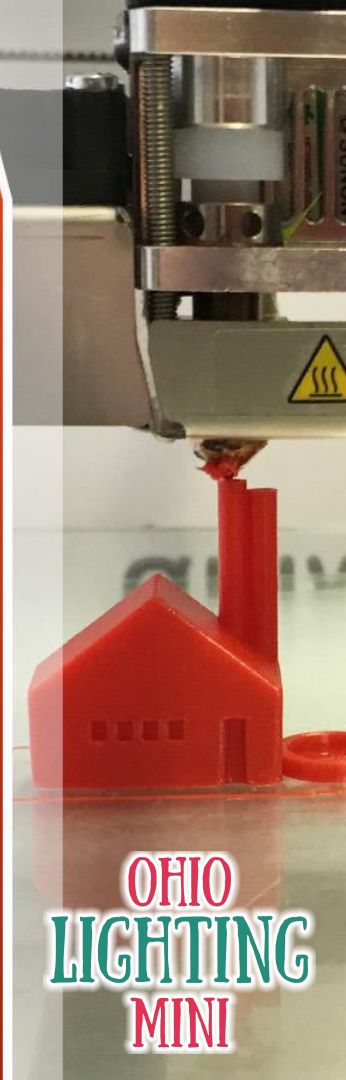

OHIO  
LIGHTING  
MINI

# Filament

- TRANSPARENT

PLA/PETG variants , tricky to get “clear”, nozzle temp, fan cooling, thin layers, vase mode

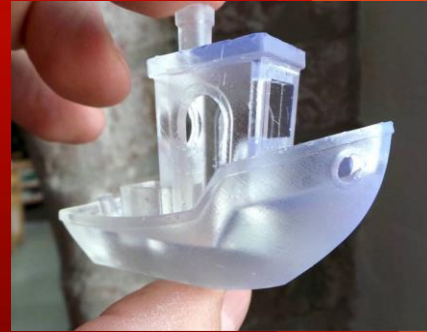

- TPU/TPE/TPC

Rubber-like, rated via Shore Hardness, very strong, NinjaFlex, softer is trickier to print

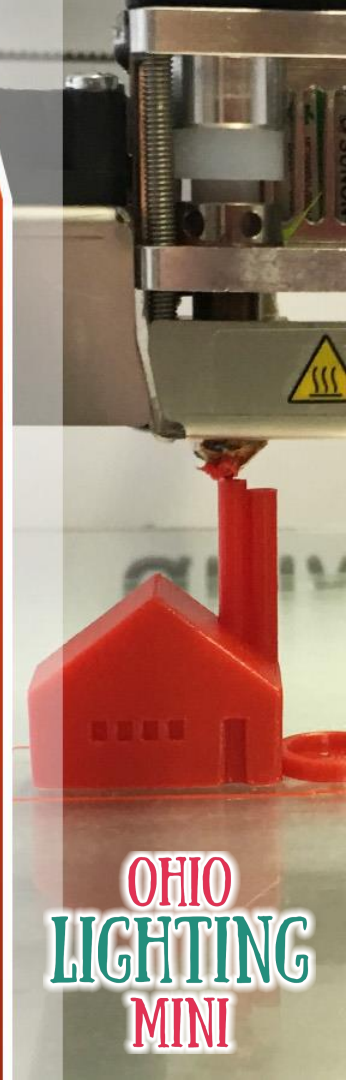

OHIO  
LIGHTING  
MINI

# Filament

- Bed & nozzle temp affects bed adhesion and layer fusion

Tweak temp. upward to improve

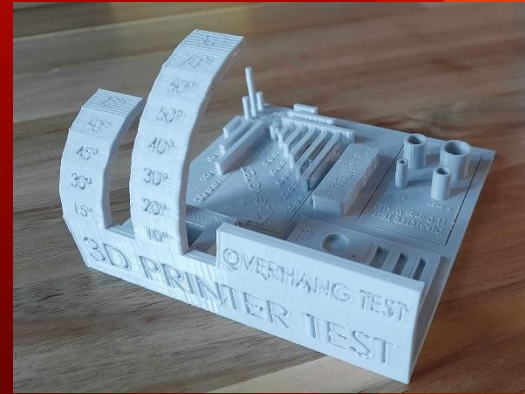

- Store in sealed bags (becomes brittle)

PETG absorbs moisture the worst

Dry in oven (low temp) or food dehydrator

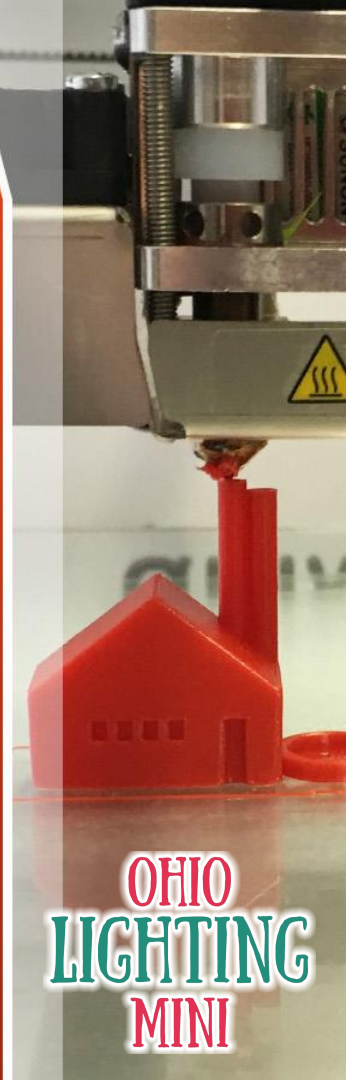

OHIO  
LIGHTING  
MINI

# TRIVIA BREAK!

What type of 3D printer was first invented, patented, and produced?

Filament

Polyjet

Sintering

Resin

# Print Bed Preparation



# Print Bed Preparation

- Build plate types
  - Flexible, glass, spring steel sheet
  - Permanent, removable
- Surfaces
  - PEI (fused/laminate), textured
- Adhesion agents
  - Glue stick, rubbing alcohol, kapton tape, hair spray (no)

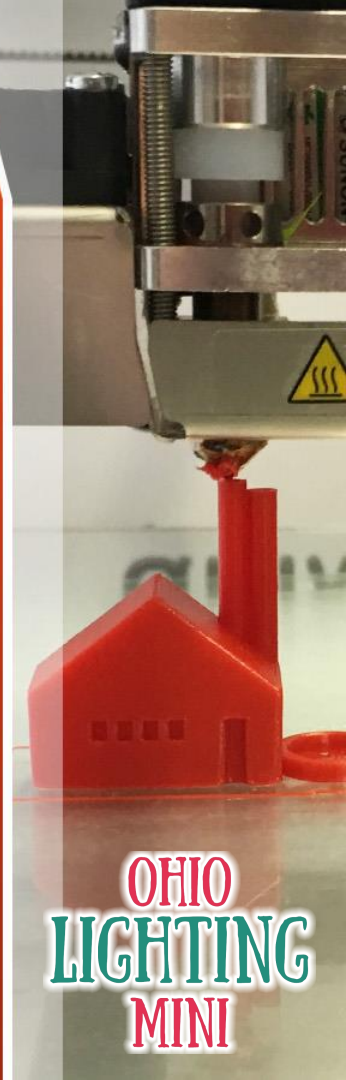

OHIO  
LIGHTING  
MINI

# Print Bed Preparation

- Bed leveling types

- Adjustable knobs (worst)

- Sheet of paper, clean nozzle, hot bed, adjust multiple times
    - Need re-adjusted over time

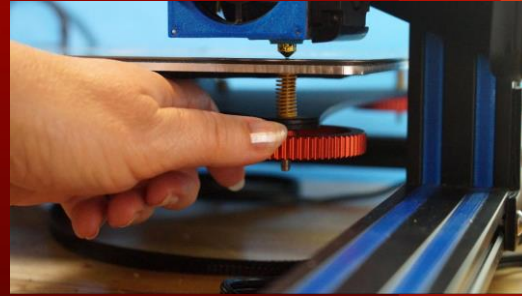

- Inductive & touch sensors (average)

- Load cell sensors (best)

- Prusa, Bambu have them

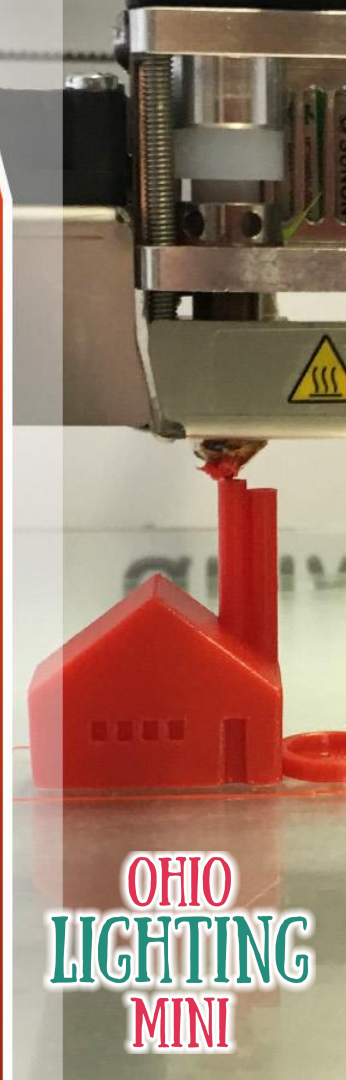

OHIO  
LIGHTING  
MINI

# First Layer Is Everything!



All3DP.com “3D Printing Troubleshooting Guide”

<https://all3dp.com/1/common-3d-printing-problems-troubleshooting-3d-printer-issues>

# First Layer Is Everything!

- Watch that line!
- Too rounded

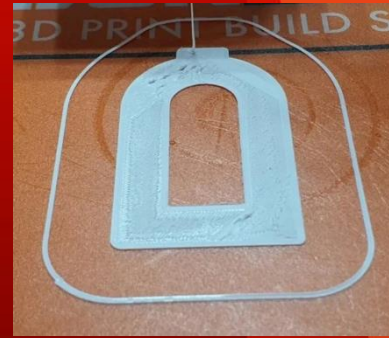

Observed: Shape does not stick to bed, lines do not fuse to adjacent lines

Causes: Extruder starting too high (Z height)

- Too flat

Observed: First layer shows wrinkles, blobbing, subsequent layers not fusing well

Cause: Extruder starting too low

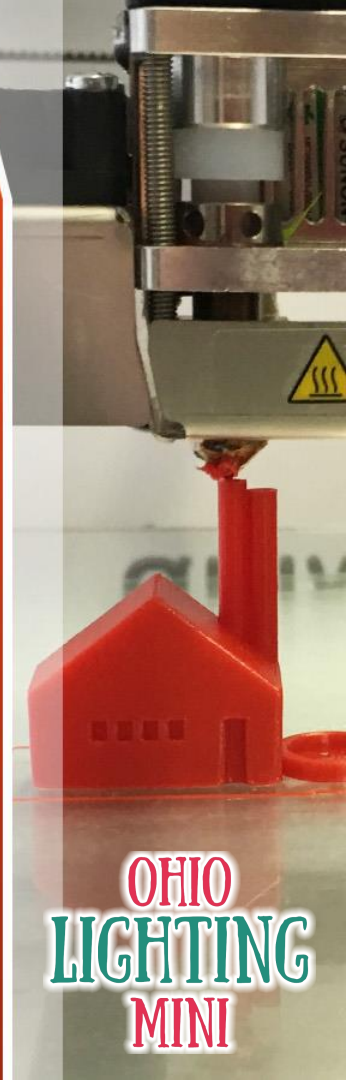

OHIO  
LIGHTING  
MINI

# First Layer Is Everything!

## Bed Leveling

Billy Ruben - <https://tinyurl.com/2bu4drst>

### ✗ MUCH TOO CLOSE

Filament extrudes thin or not at all in some places, often bulging out in others. Extruder motor might slip/click

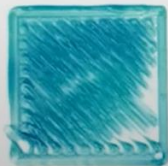

### ✗ A LITTLE TOO CLOSE

Filament bulges out of the sides of the nozzle which squishes into other lines, sometimes causing a pattern

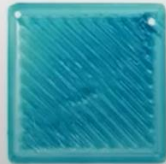

### ✓ PERFECT

Filament is flattened, adheres well to nearby lines, no gaps or peaks between lines



### ✗ A LITTLE TOO FAR

Filament appears rounded, connection between lines is loose, gaps may appear

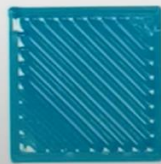

### ✗ MUCH TOO FAR

Filament is totally rounded, little to no connection between lines, doesn't stick to bed

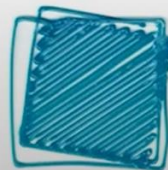

OHIO  
LIGHTING  
MINI

# First Layer Is Everything!

- Perfect first layer
  - Filament should slightly squish into bed
  - First layer is smooth (no wrinkles)
  - Lines should move if prodded
- Some solutions
  - Calibrate Z Height
  - Clean bed with rubbing alcohol
  - Apply thin layer of glue stick
  - Hotter nozzle temp, turn off fan for 1<sup>st</sup> layer

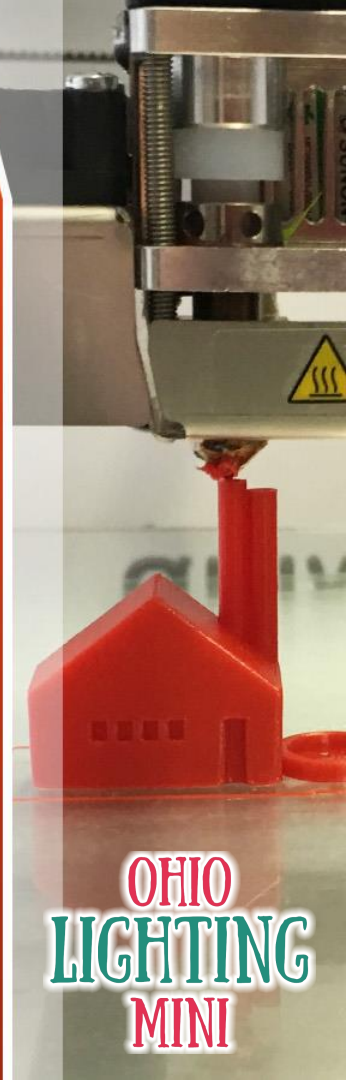

OHIO  
LIGHTING  
MINI

# TRIVIA BREAK!

What was the first object electronically sent to the Space Shuttle and 3D printed in space?

Screwdriver

Rocky

Ratchet

Pliers

# Slicer Choices



**Slic3r**

G-code generator for 3D printers

# Slicer Choices

- Slicer that comes with printer
  - Custom made or may be a derivative of popular slicers
  - Finely tuned for your printer
- Popular slicers
  - PrusaSlicer, Bambu Studio, Cura, OrcaSlicer

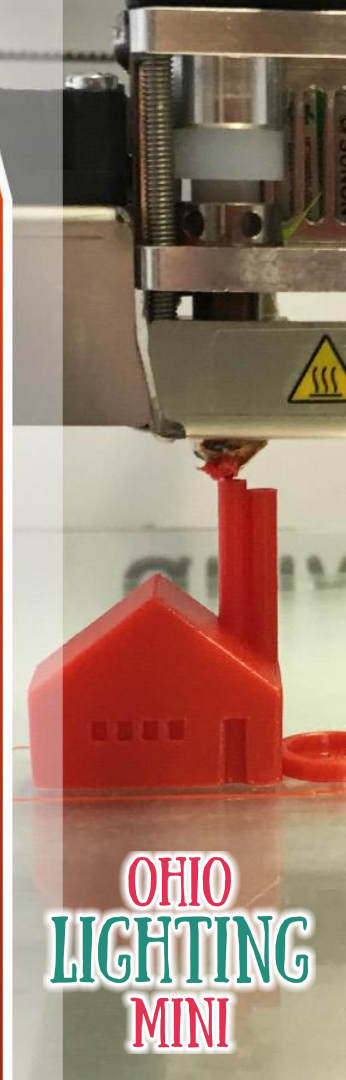

OHIO  
LIGHTING  
MINI

# TRIVIA BREAK!

What was the first 3D printed object on the first commercially made 3D printer?

Eyewash cup

Machining jig

Control knob

Gumby

# Orientation, Scaling, Cutting

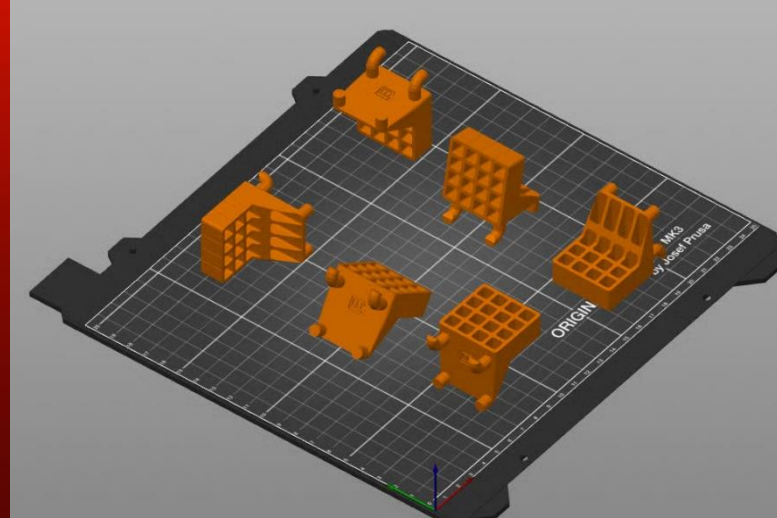

# Orientation, Scaling, Cutting

- Moving shapes around
- Rotating
  - Free form vs. arrows, flat side down
  - Orientation affects part strength!
- Scaling
  - Where to view shape size
  - Free form vs. degrees vs. percentages
- Cutting
  - Removing unwanted features

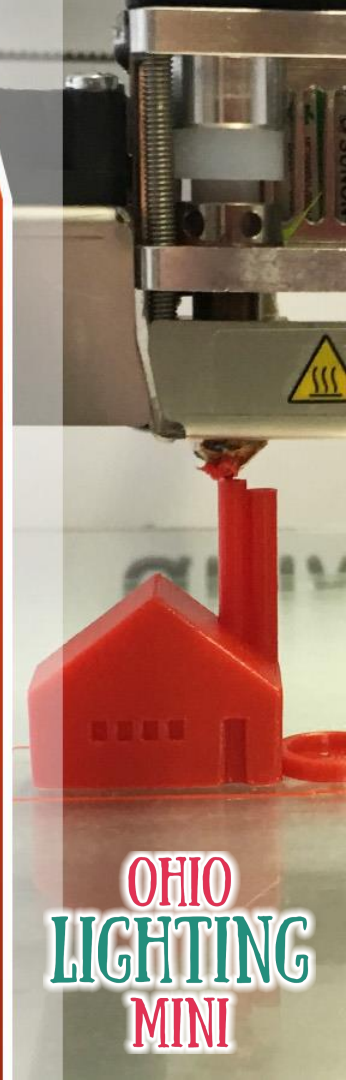

OHIO  
LIGHTING  
MINI

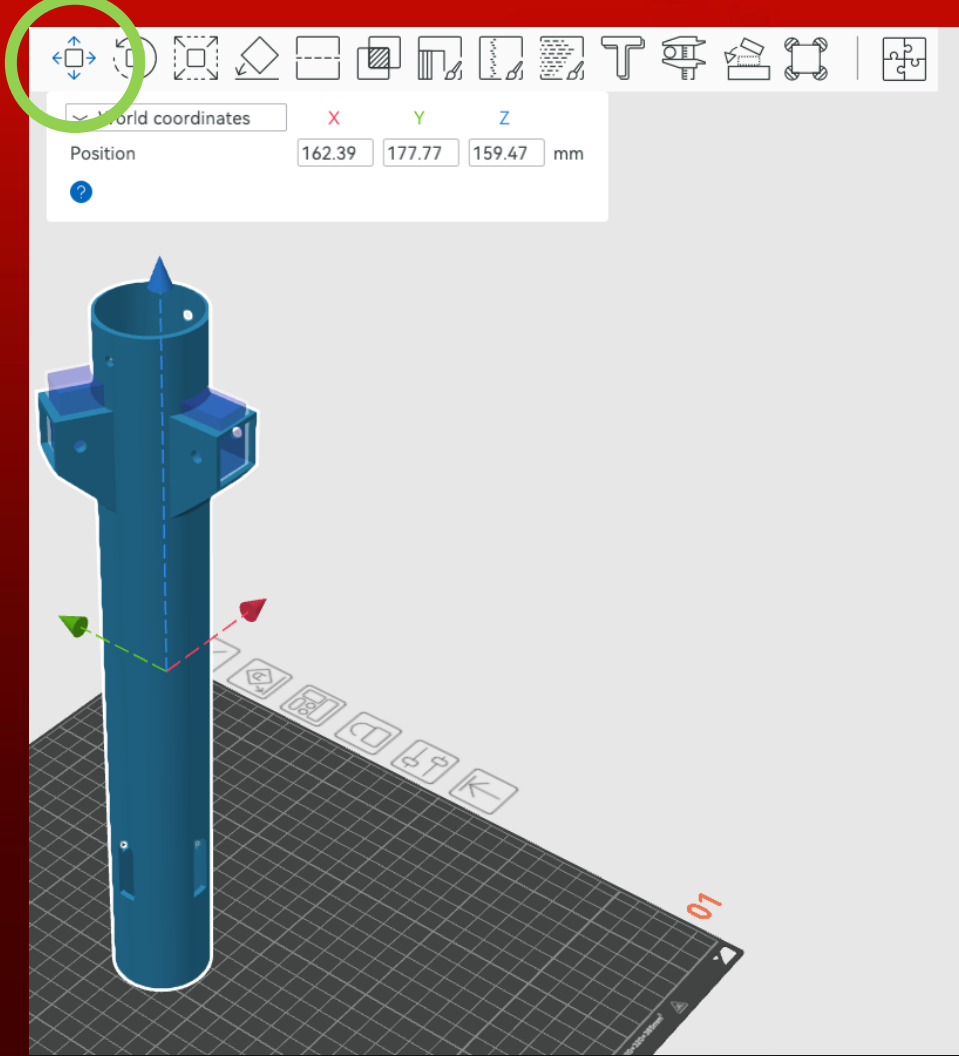

OHIO  
LIGHTING  
MINI

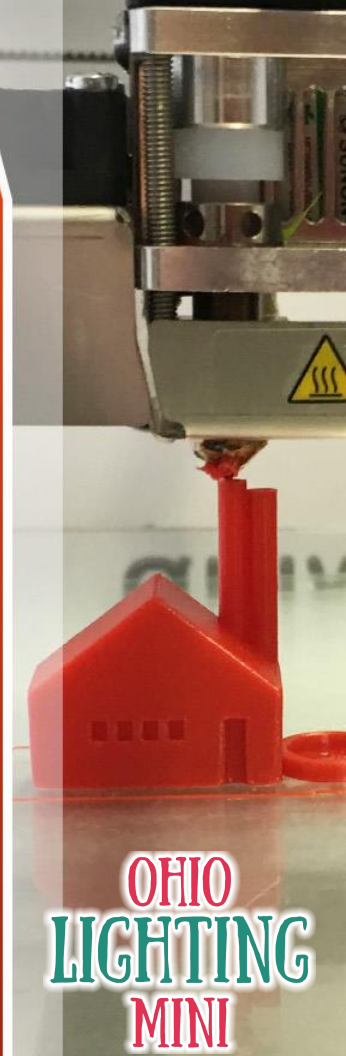
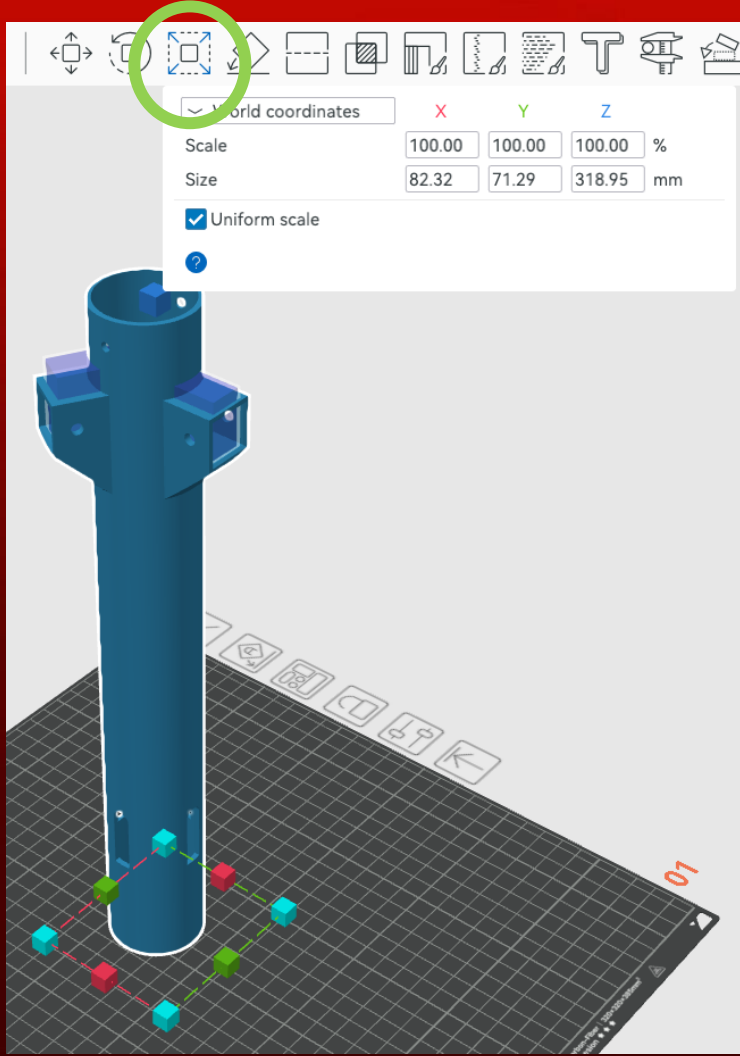

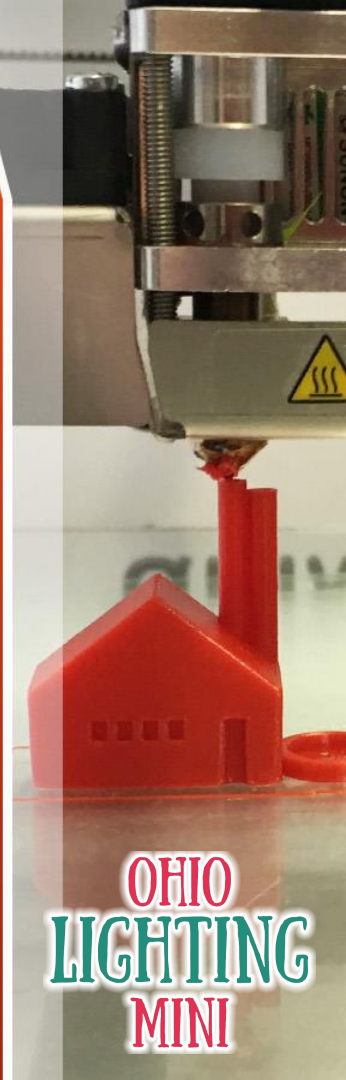
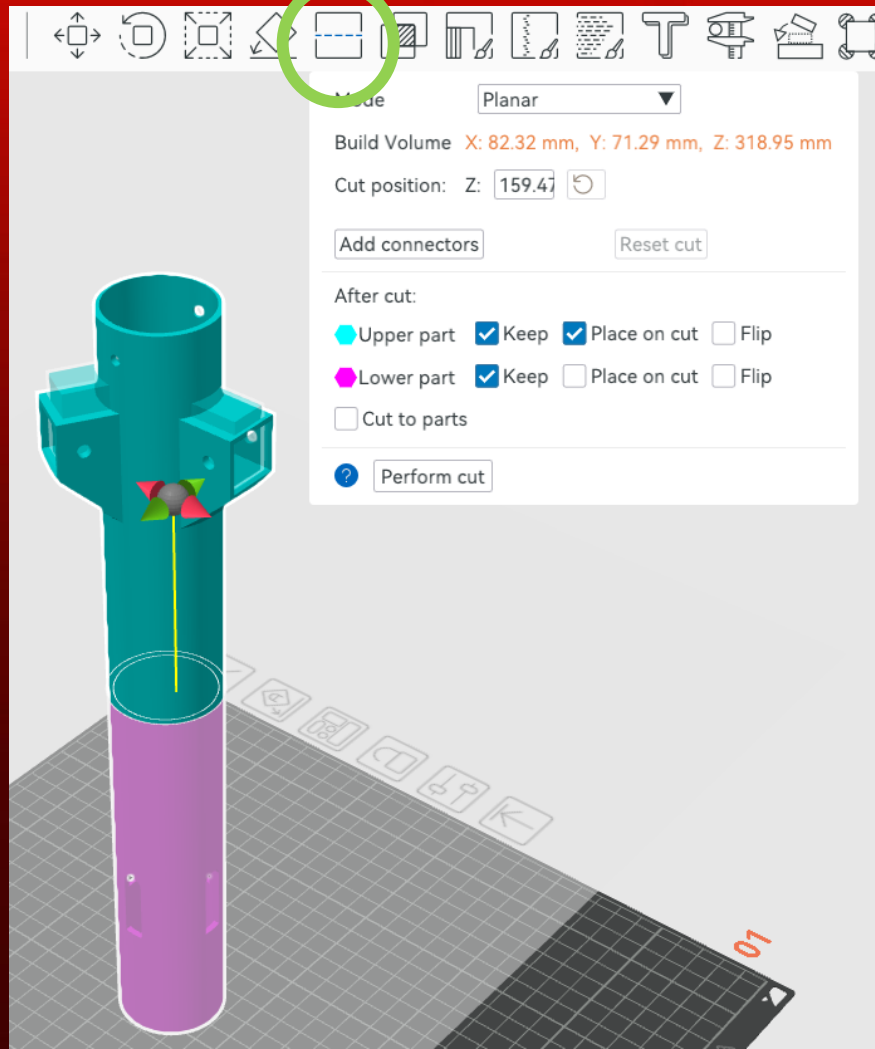

# Supports, Brims, Skirts



# Supports, Brims, Skirts

- Support types
  - Rectilinear/grid, organic/tree
- Importance & problems w/supports
- 45-degree angle rule
- Support blockers
- Support enforcers
- First-layer calibration is important!
- Brims and skirts

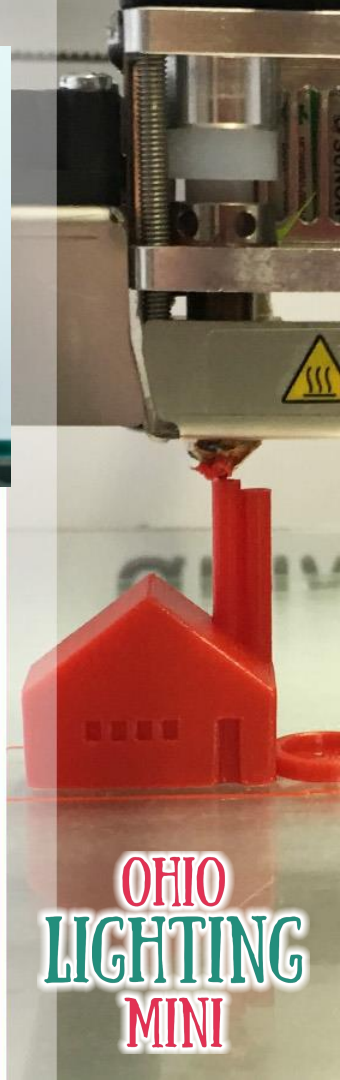
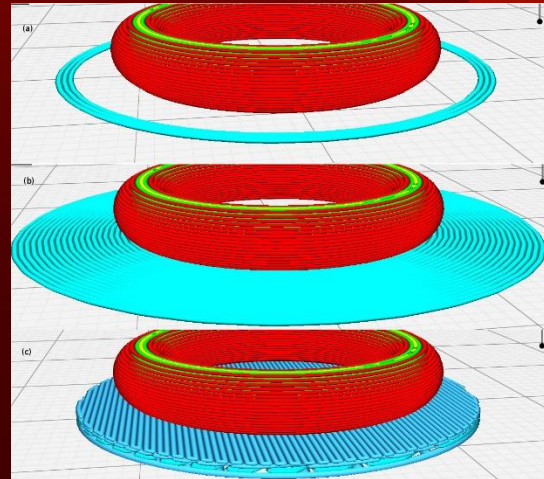
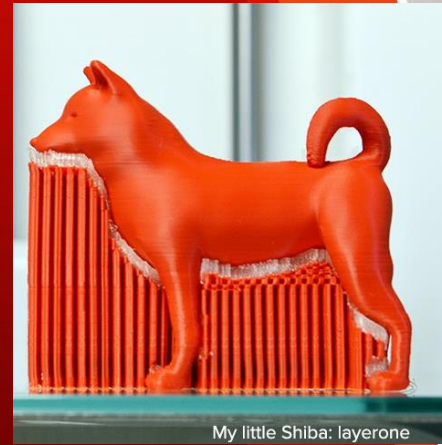

# Supports

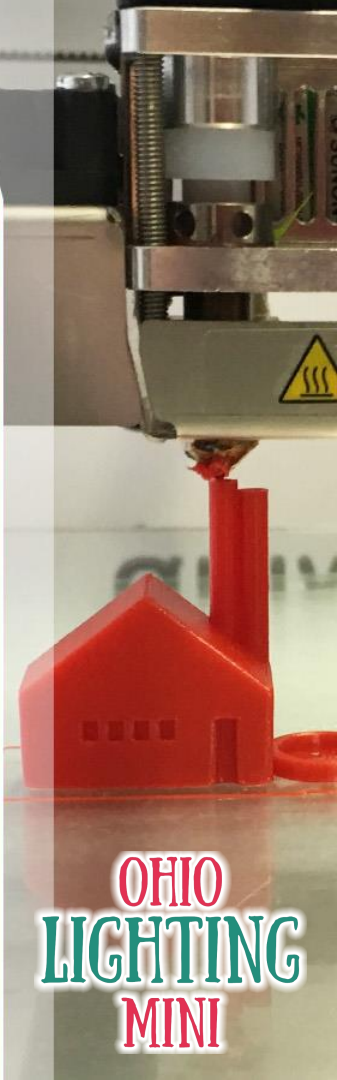
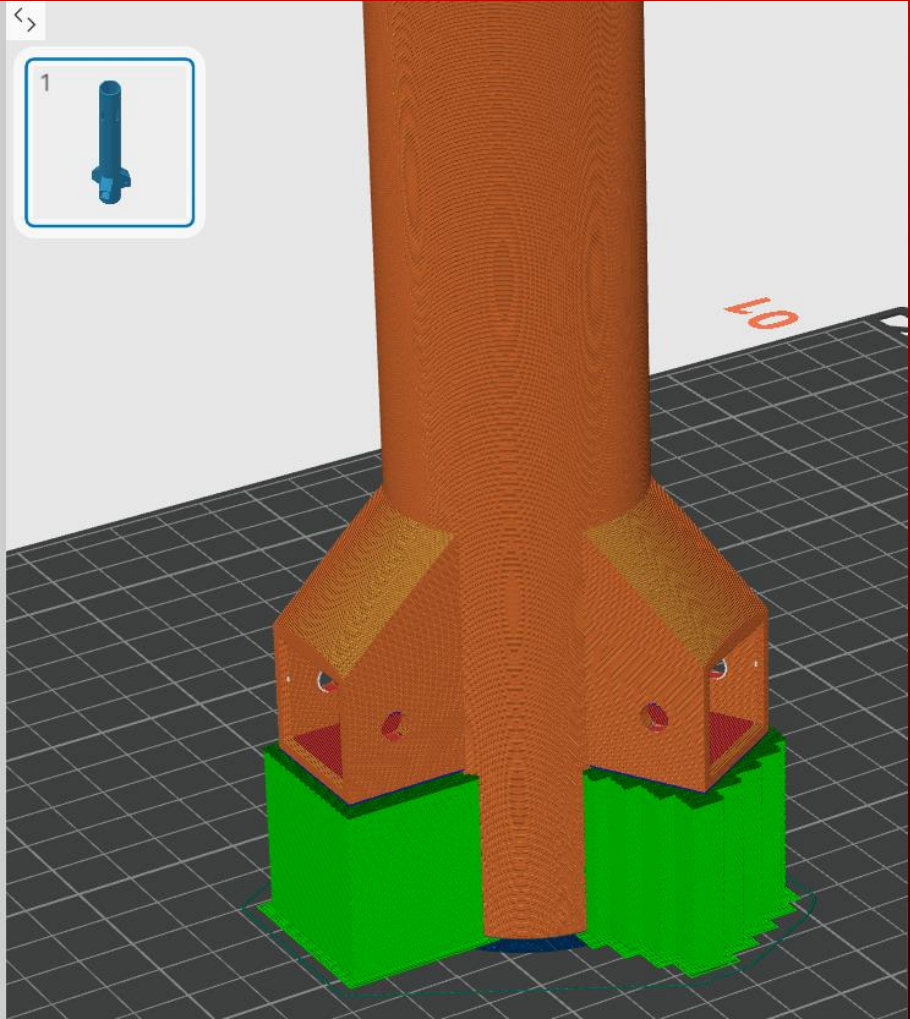

OHIO  
LIGHTING  
MINI

Too many supports

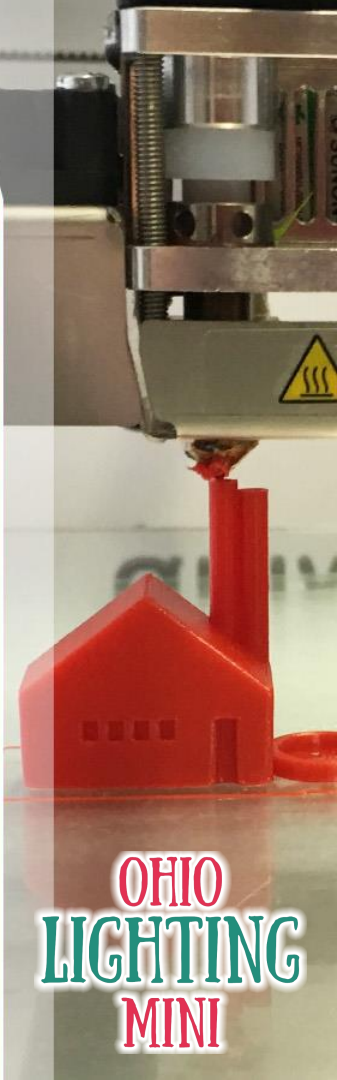
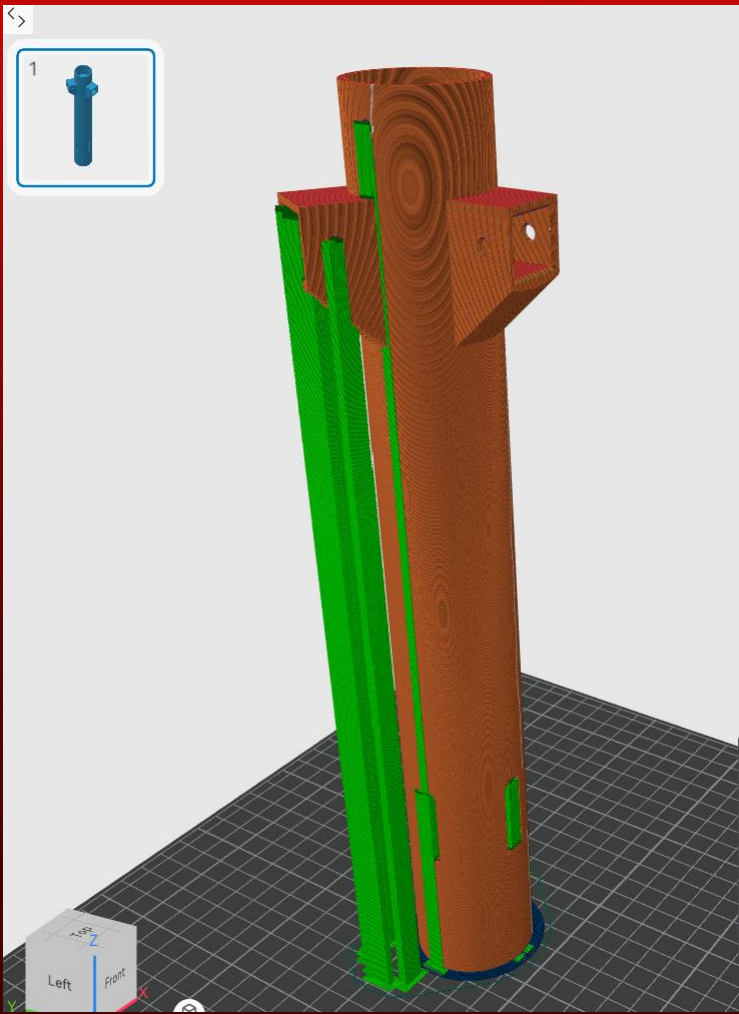

OHIO  
LIGHTING  
MINI

Support  
enforcers

with  
supports  
on build  
plate  
disabled

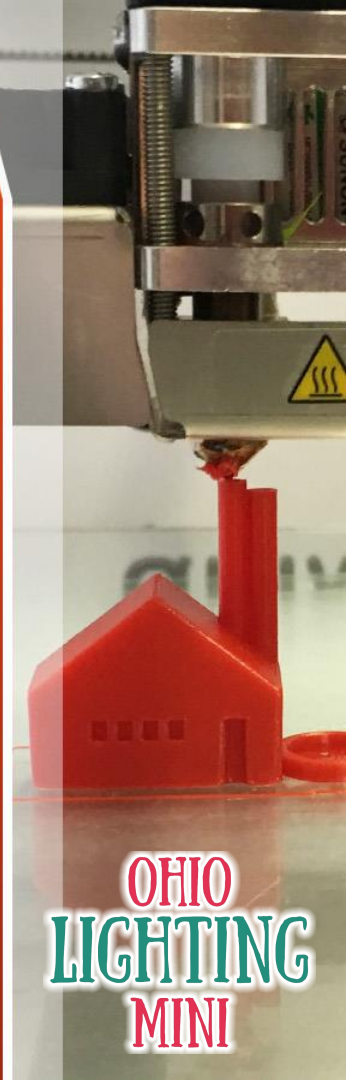
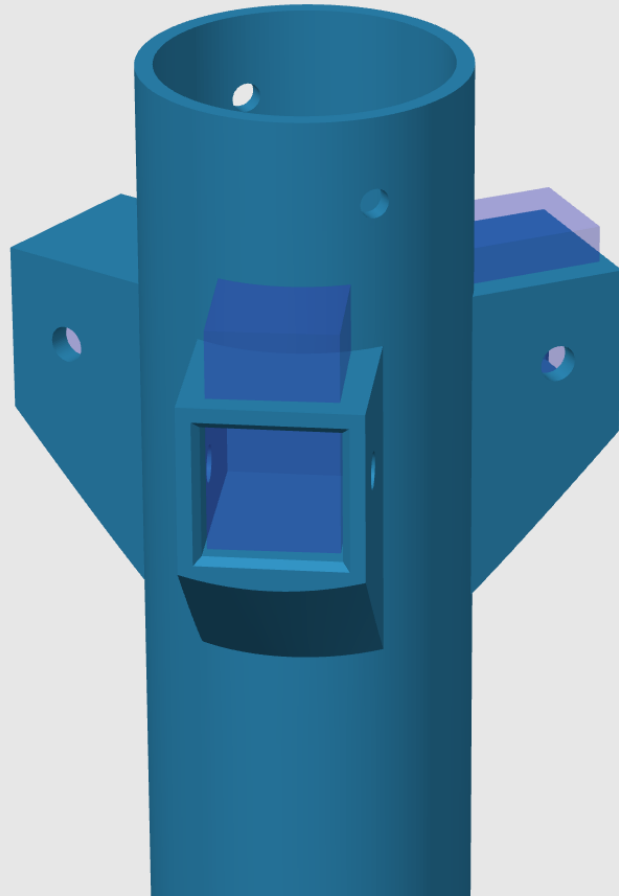

OHIO  
LIGHTING  
MINI

# Support enforcers results

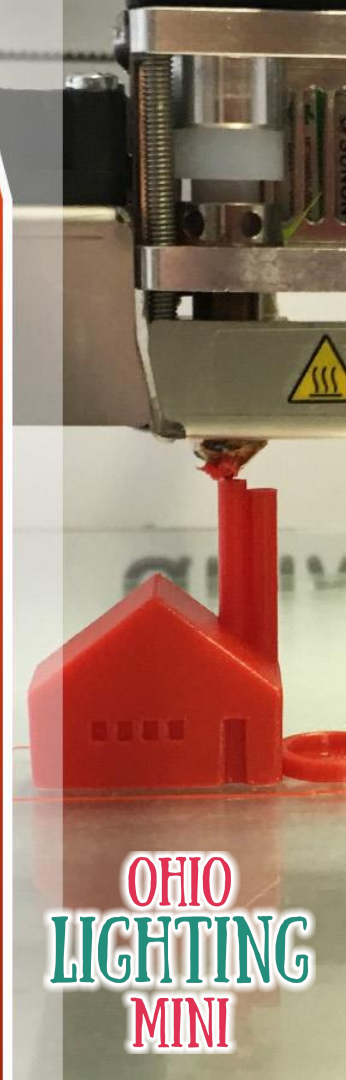
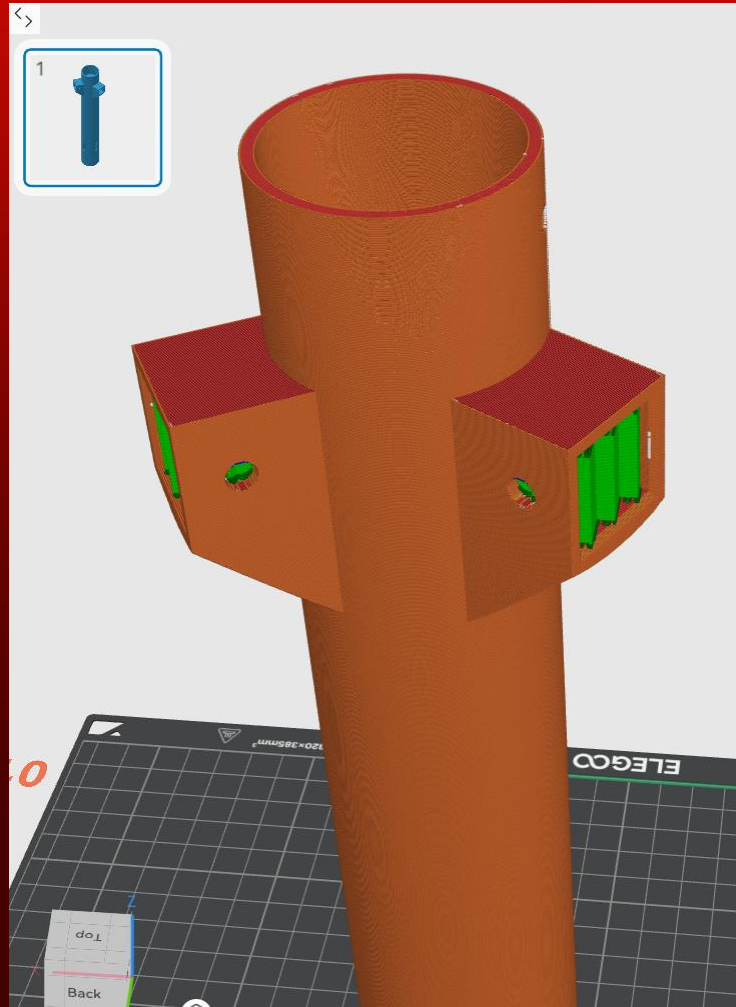

OHIO  
LIGHTING  
MINI

# TRIVIA BREAK!

What was the first 3D printed and successfully transplanted human organ?

Windpipe

Bladder

Heart

Ear

# Layer Height, Infill, Walls

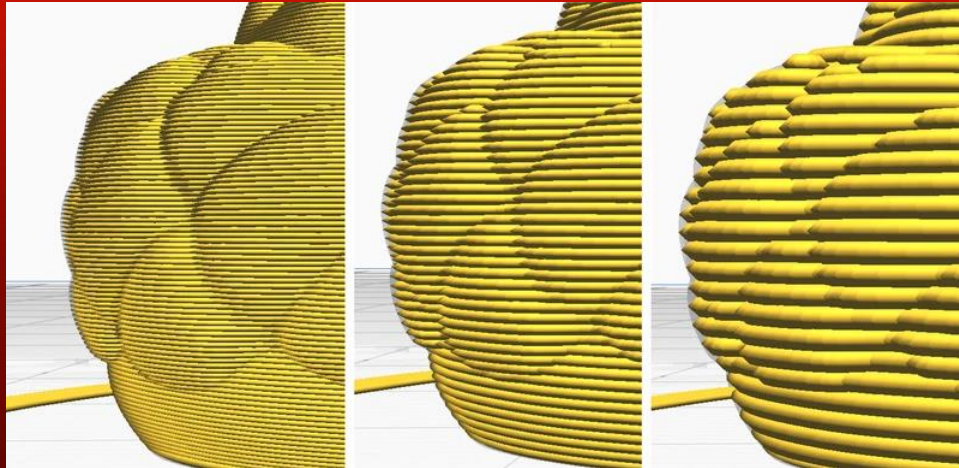

# Layer Height, Walls, Infill

- Layer Height

Thicker layer height = faster printing

40% of nozzle width (0.32mm layer height max for 0.4mm nozzle)

Can slightly negatively impact vertical holes

Try larger nozzles (>0.40mm)

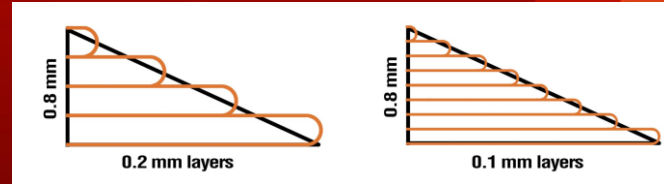

- Walls (aka perimeters)

- Default is 0.4mm (two lines)

- 0.8mm strengthens screw hole, allows overall strength while keeping infill low

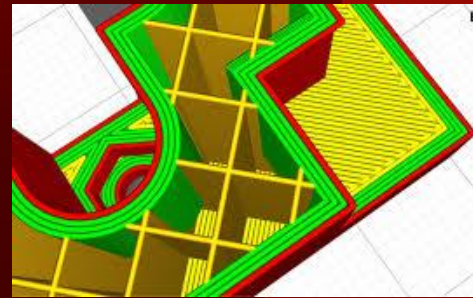

OHIO  
LIGHTING  
MINI

# Layer Height, Walls, Infill

- Infill

Default is 15%, 30% is good

Too much infill = wasted time and filament

Better to have less infill yet thicker walls

Use 90% fill for super strength

Different fill types yield different strengths

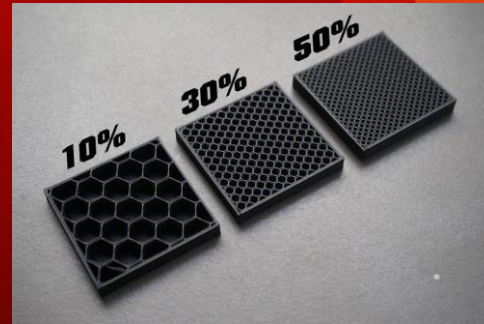

<https://all3dp.com/2/strongest-infill-pattern>

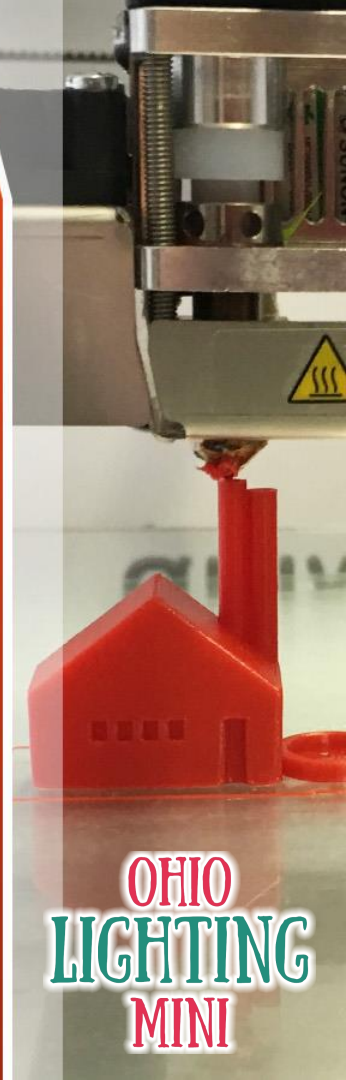

OHIO  
LIGHTING  
MINI

# TRIVIA BREAK!

In the James Bond movie Skyfall, which vehicle was 3D printed full-size for 3 explosion scenes?

Aston Martin DB5

Yugo

Jaguar X-X75

Mercedes S400

# Printing



# Printing

- Flash drive: Hassle, but reliable. Reprinting easy.
- Wi-Fi/network: Computer crashes, so does your printer
- Do not print overnight or unattended
- After printing
  - Let bed cool to 32C , prevents part warping
  - Remove print bed first (if possible)
  - Be careful using scraper on bed or supports

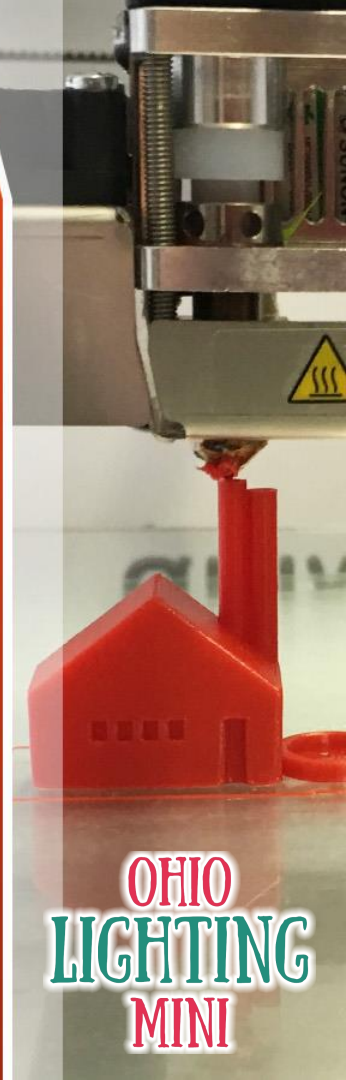

OHIO  
LIGHTING  
MINI

# Getting Help



# Getting Help

- All3DP.com  
Get on their mailing list
- Facebook support groups for your printer
- Area makerspaces  
Local libraries, Akron Makerspace, Case Western think[box], more

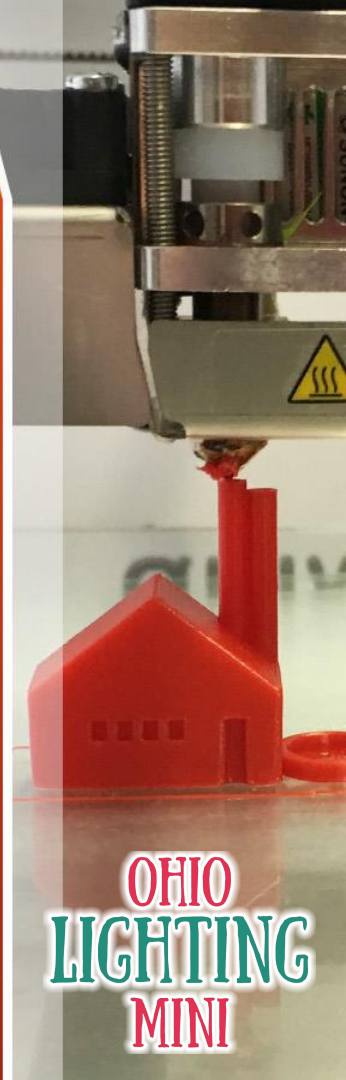
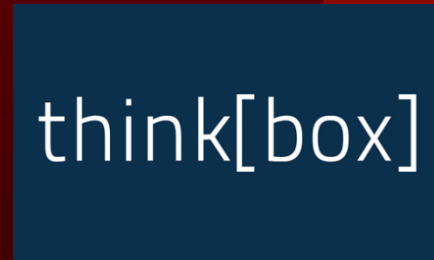
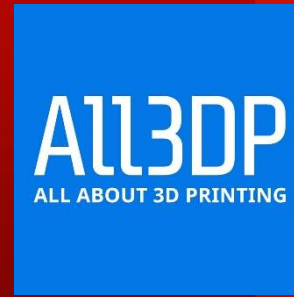

**Thank You!**

Tom Hammond

**Phone**

330-658-3872

**Email**

[tominohio@gmail.com](mailto:tominohio@gmail.com)

**Website**

[itwinkle.org](http://itwinkle.org)

**OHIO  
LIGHTING  
MINI**

